

MICRO DIAPHRAGM GAS SAMPLING PUMPS

DATA SHEET E 004

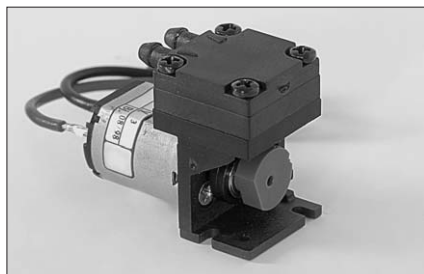

NMP 05 S

Concept

The Micro Diaphragm Gas Sampling Pumps from KNF are based on a simple principal - an elastic diaphragm, fixed on its edge, moves up and down its central point by means of an eccentric. In this way the medium is transferred using automatic valves.

The new range of KNF Micro Pumps is for the first time equipped with the patented stress-optimised structured diaphragm, resulting in a high pneumatic performance, a durable product and compact size. New, very efficient valves and sealing systems as well as the precise placement of the pump head are some of the other technical features we can offer.

For pump drive we provide a selection of dc motors with various levels of performance, durability and price.

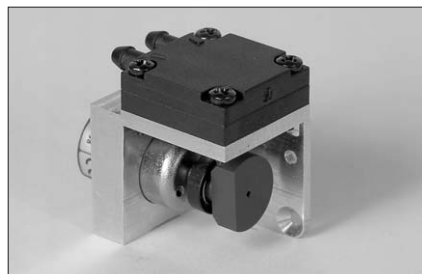

NMP 09 M

Features

Uncontaminated flow

No contamination of the media due to oil-free operation

Maintenance-free

Compact size

due to structured diaphragm

High pneumatic performance

because of structured diaphragm

High level of gas tightness

thanks to the closed diaphragm surface and special sealing system

Low aerodynamic loss

by means of a new valve system

Long product life

thanks to structured diaphragm

Ready for assembly

Can operate in any installed position

For the version with brushless motor the following also apply:

- no sparks
- safe and reliable constant use
- particularly long durability

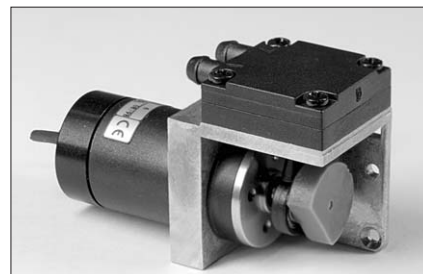

NMP 015 B

Areas of use

KNF Micro Diaphragm Pumps are used frequently in the fields of analysis and medicine.

For instance as pumps for gas measurement, for example for sampling environmental conditions in the workplace, or for exhaust gas and smoke analysis or built into machines for measuring blood pressure.

As they are dc driven, the micro diaphragm pumps are suited for use in portable and stand-alone equipment.

PERFORMANCE DATA

Type	Delivery (l/min)	Vacuum (mbar absolute)	atm. Press.	Pressure (bar g)	Weight (g)
NMP 05 S (Standard dc motor, 5V)	0.40	500		0.15	18.0
NMP 05 M (dc motor with iron-free rotor, 6V)	0.40	500		0.15	19.5
NMP 05 L (dc motor with iron-free rotor, longlife)	0.45	500		0.25	27.0
NMP 05 B (brushless dc motor)	0.30	500		0.4	22.0
NMP 09 S (Standard dc motor)	0.75	550		0.15	19.5
NMP 09 M (dc motor with iron-free rotor)	0.85	500		0.15	22.5
NMP 09 L (dc motor with iron-free rotor, longlife)	0.85	500		0.25	29.5
NMP 09 B (brushless dc motor)	0.75	500		0.65	24.5
NMP 015 S (Standard dc motor)	1.4	400		0.9	44.0
NMP 015 M (dc motor with iron-free rotor)	1.6	400		0.9	65.0
NMP 015 L (dc motor with iron-free rotor, longlife)	1.4	400		0.9	47.0
NMP 015 B (brushless dc motor)	1.3	400		0.9	55.0

More information about dc motors you find inside.

NMP 05 S NMP 05 M

PERFORMANCE DATA

Type and Order No. ²⁾	DC Motor (V)	Delivery at atm. pressure (l/min) ³⁾	Max. operating pressure (mbar)	Ultimate vacuum (mbar abs.)
NMP 05 S	3	0.25	±150	600
NMP 05 S	5	0.4	±150	500
NMP 05 M	6	0.3	±150	500
NMP 05 M	2.5	0.4	±150	550

³⁾ Litre at STP

²⁾ „DRIVE OPTIONS“ (DC Motor Version) and „MODEL CODE EASY ORDERING“; see the next page.

MODEL CODES AND MATERIALS

Pump head	Diaphragm	Valves
Ryton ⁴⁾	EPDM	EPDM

Dimensions ³⁾ (mm)

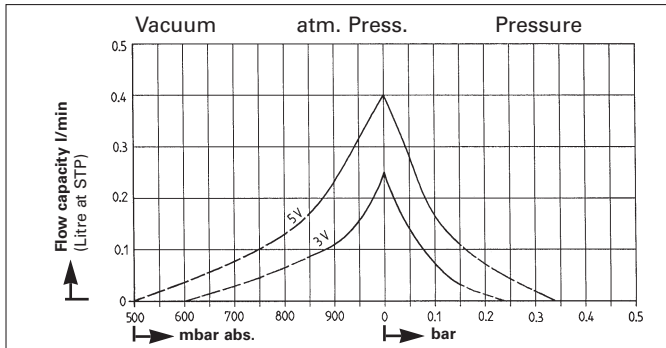
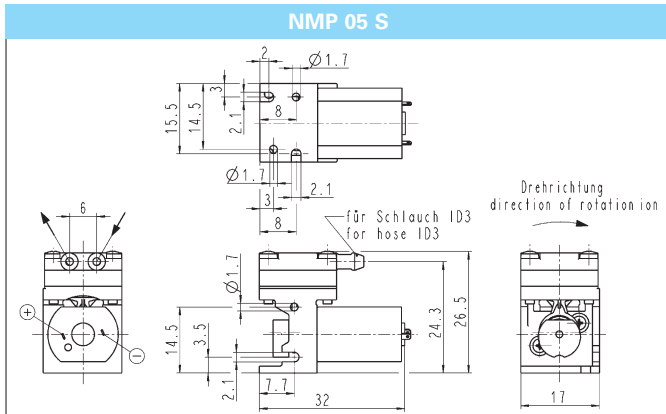

NMP 05 L NMP 05 B

PERFORMANCE DATA

Type and Order No. ²⁾	DC Motor (V)	Delivery at atm. pressure (l/min) ³⁾	Max. operating pressure (mbar)	Ultimate vacuum (mbar abs.)
NMP 05 L	6	0.45	±250	500

NMP 05 L correspond with the EC directive concerning electro-magnetical compatibility 89/336 EWG.

PERFORMANCE DATA (version with brushless dc motor)

Type and Order No. ²⁾	DC Motor (V)	Delivery at atm. pressure (l/min) ³⁾	Ultimate pressure (mbar)	Ultimate vacuum (mbar abs.)
NMP 05 B	6	0.3	400	500

Caution! Incorrect lead connection will damage motor electronics!

MODEL CODES AND MATERIALS

Pump head	Diaphragm	Valves
Ryton ⁴⁾	EPDM	EPDM

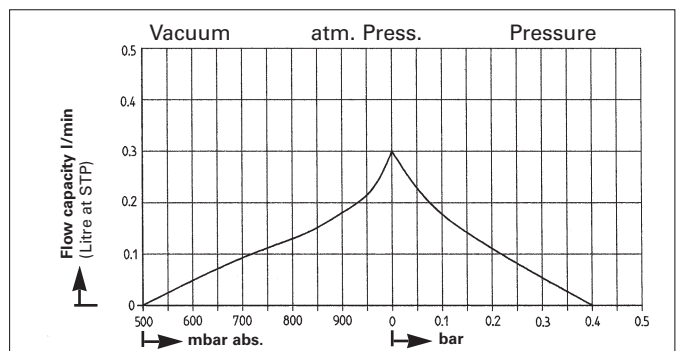
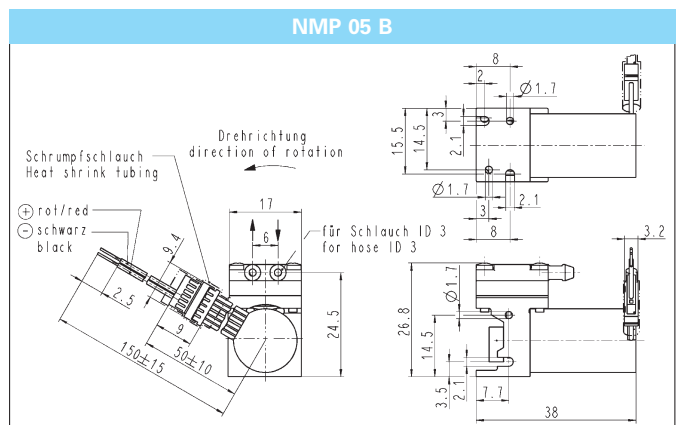
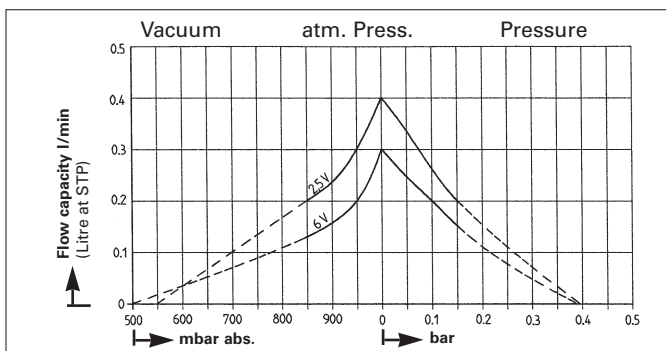
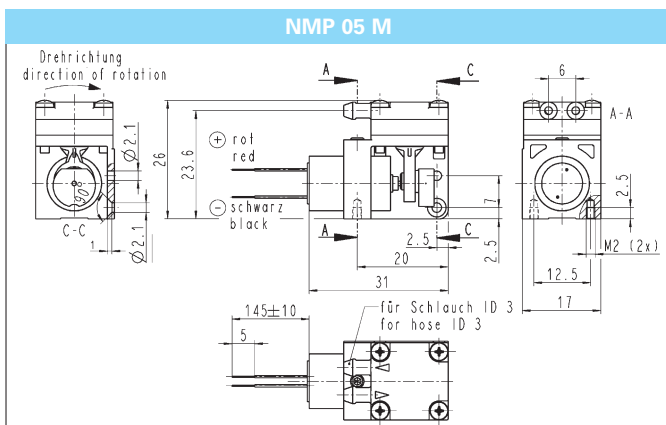
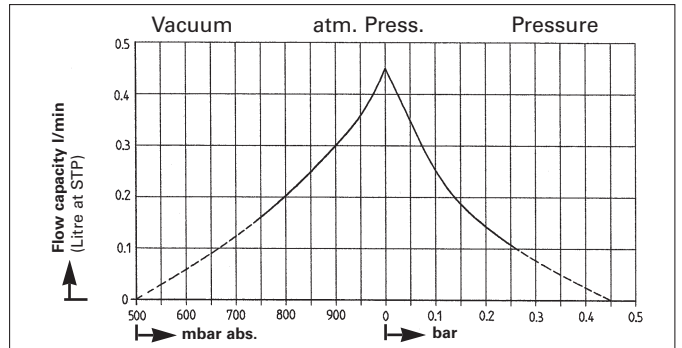
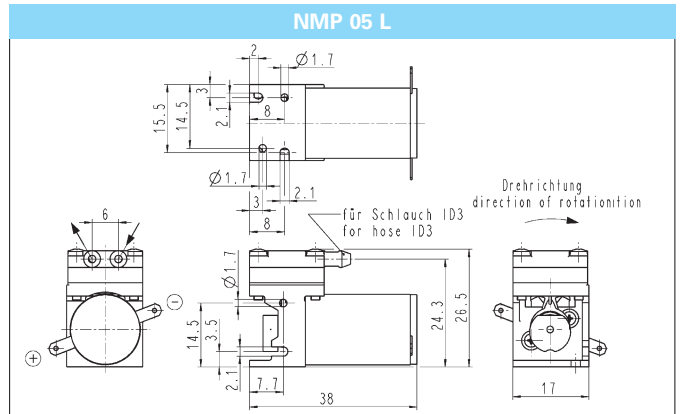

----- for short periods only

³⁾ All dimensional tolerances conform to DIN ISO 2768-1, Tolerance Class V

NMP 09 S NMP 09 M

PERFORMANCE DATA

Type and Order No. ²⁾	DC Motor (V)	Delivery at atm. pressure (l/min) ¹⁾	Max. operating pressure (mbar)	Ultimate vacuum (mbar abs.)
NMP 09 S	3	0.65	±150	550
NMP 09 S	5	0.75	±150	550
NMP 09 M	6	0.8	±150	500
NMP 09 M	2.5	0.85	±150	500

¹⁾ Litre at STP

²⁾ „DRIVE OPTIONS“ (DC Motor Version) and „MODEL CODE EASY ORDERING“ see the next page.

MODEL CODES AND MATERIALS

Pump head	Diaphragm	Valves
Ryton ⁴⁾	EPDM	EPDM

Dimensions ³⁾ (mm)

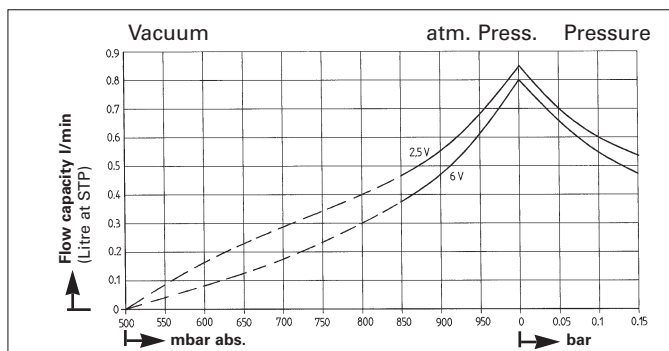
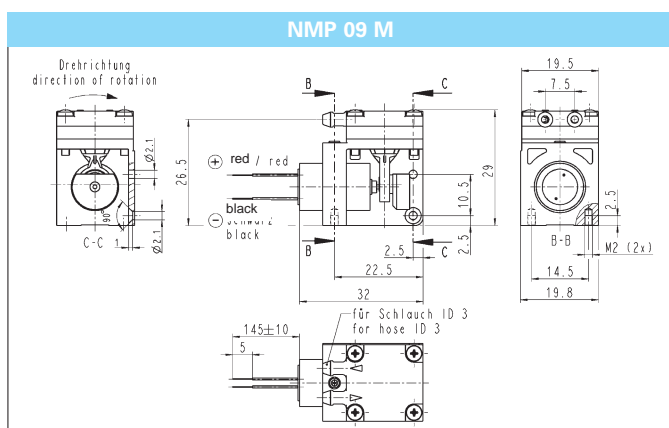
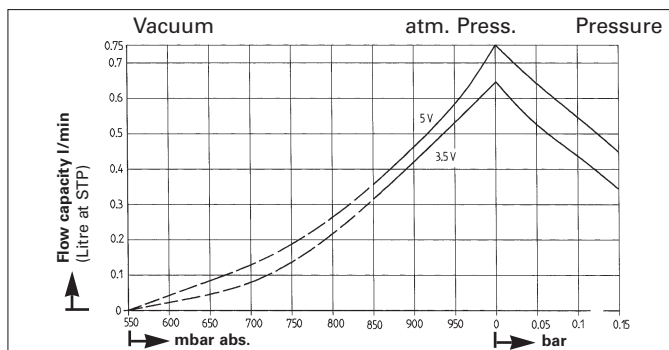
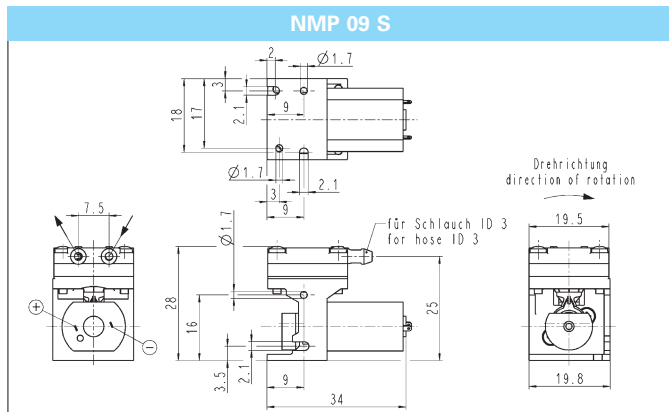

NMP 09 L NMP 09 B

PERFORMANCE DATA

Type and Order No. ²⁾	DC Motor (V)	Delivery at atm. pressure (l/min) ¹⁾	Max. operating pressure (mbar)	Ultimate vacuum (mbar abs.)
NMP 09 L	6	0.85	±250	500

NMP 09 L correspond with the EC directive concerning electro-magnetical compatibility 89/336 EWG.

PERFORMANCE DATA (version with brushless dc motor)

Type and Order No. ²⁾	DC Motor (V)	Delivery at atm. pressure (l/min) ¹⁾	Ultimate pressure (mbar)	Ultimate vacuum (mbar abs.)
NMP 09 B	6	0.75	650	500

Caution! Incorrect lead connection will damage motor electronics!

MODEL CODES AND MATERIALS

Pump head	Diaphragm	Valves
Ryton ⁴⁾	EPDM	EPDM

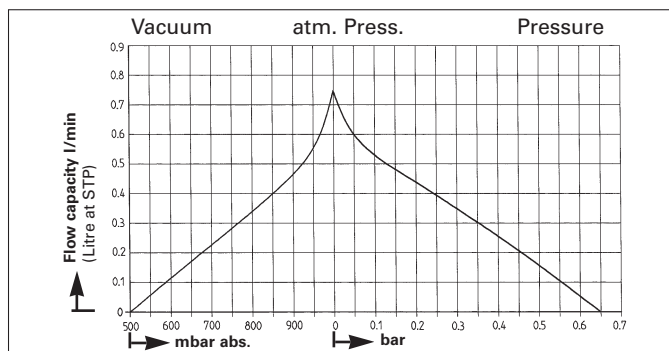
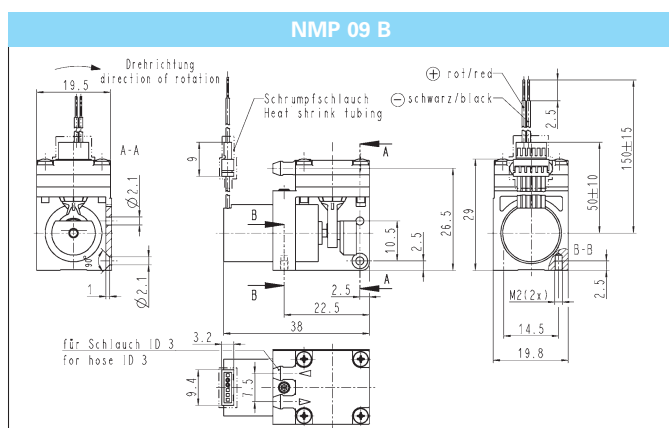
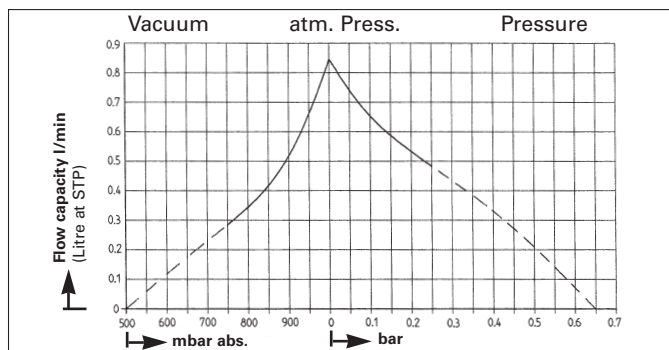
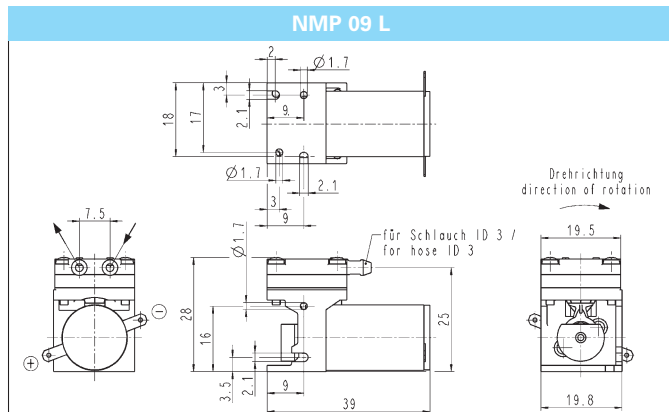

NMP 015 S NMP 015 M

PERFORMANCE DATA

Type and Order No. ²⁾	DC Motor (V)	Delivery at atm. pressure (l/min) ¹⁾	Max. operating pressure (mbar)	Ultimate vacuum (mbar abs.)	Ultimate pressure (bar g)
NMP 015 S	3.5	1.4	±200	400	0.9
NMP 015 S	6	1.4	±200	400	0.9
NMP 015 M	6	1.5	±200	400	0.9
NMP 015 M	12	1.6	±200	400	0.9

¹⁾ Litre at STP

²⁾ „DRIVE OPTIONS“ (DC Motor Version) and „MODEL CODE EASY ORDERING“; see the next page.

MODEL CODES AND MATERIALS

Pump head	Diaphragm	Valves
Ryton ⁴⁾	EPDM	EPDM

NMP 015 L NMP 015 B

PERFORMANCE DATA

Type and Order No. ²⁾	DC Motor (V)	Delivery at atm. pressure (l/min) ¹⁾	Max. operating pressure (mbar)	Ultimate vacuum (mbar abs.)	Ultimate pressure (bar g)
NMP 015 L	3.5	1.3	±250	400	0.9
NMP 015 L	6	1.4	±250	400	0.9

NMP 015 L correspond with the EC directive concerning electro-magnetical compatibility 89/336 EVG.

PERFORMANCE DATA (version with brushless dc motor)

Type and Order No. ²⁾	DC Motor (V)	Delivery at atm. pressure (l/min) ¹⁾	Ultimate vacuum (mbar abs.)	Ultimate pressure (bar g)
NMP 015 B	6	1.3	400	0.9
NMP 015 B	12	1.3	400	0.9

Caution! Incorrect lead connection will damage motor electronics!

MODEL CODES AND MATERIALS

Pump head	Diaphragm	Valves
Ryton ⁴⁾	EPDM	EPDM

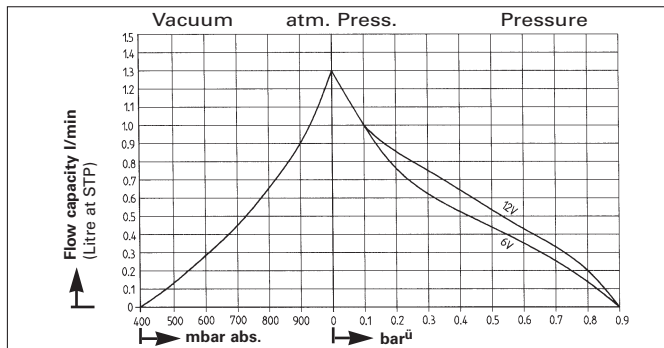
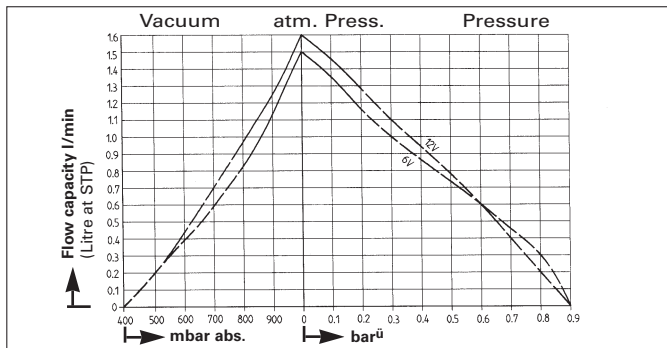
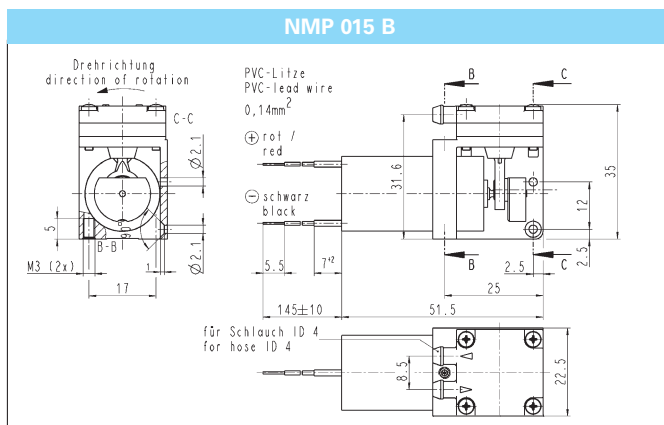
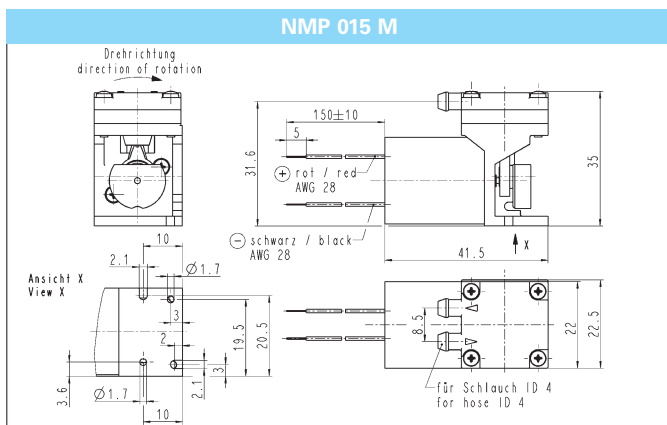
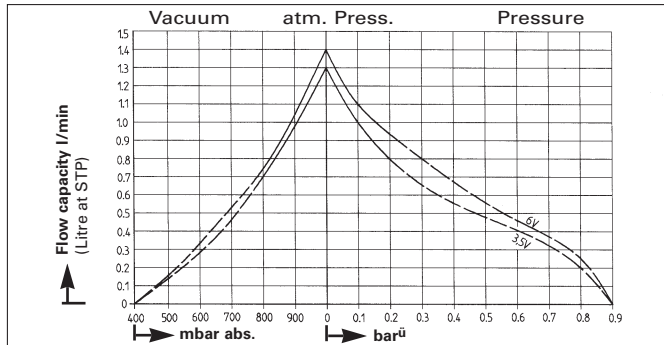
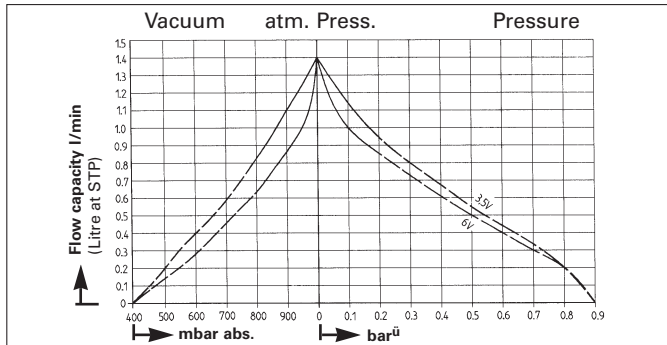
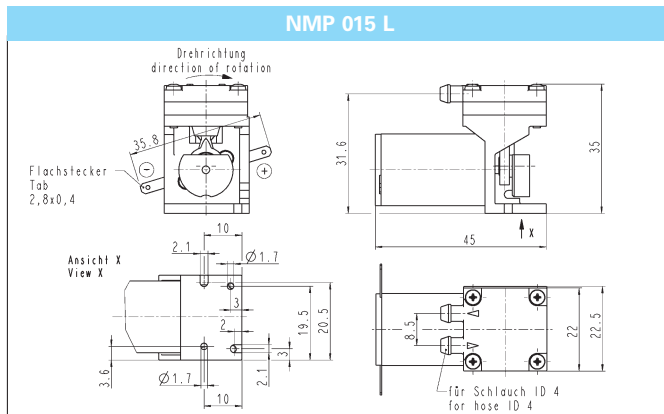
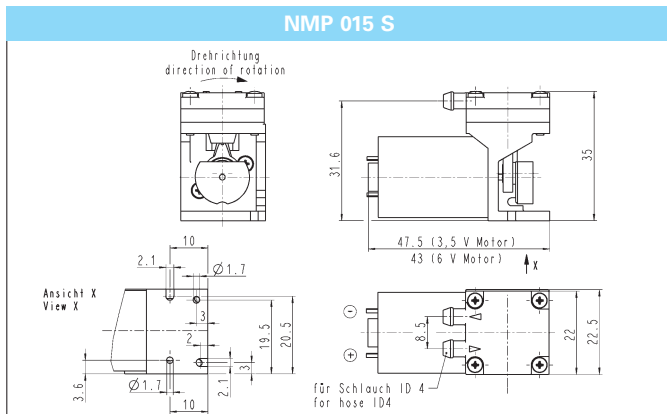

MICRO DIAPHRAGM GAS SAMPLING PUMPS WITH THE WORLD SMALLEST STRUCTURED DIAPHRAGM!

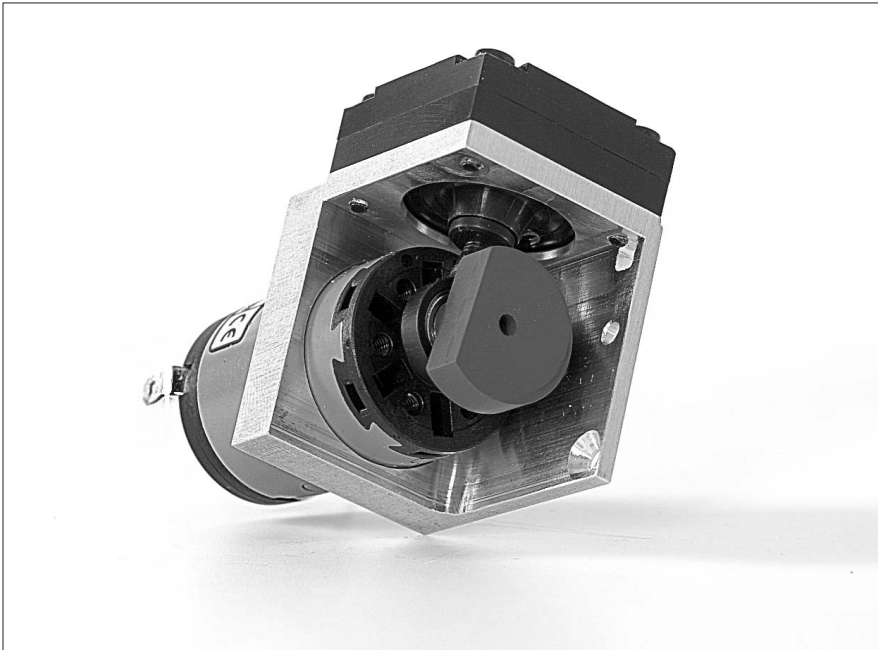

TECHNICAL DETAILS

Maximum permissible gas and ambient temperature: between +5°C and +40°C.

Motors with other voltages on request.

⁴⁾ Phillips Petroleum registered trademark.

Hints on function and installation: see back side.

MODEL CODE FOR EASY ORDERING

The model code is identical to the order number. It is made up as follows:

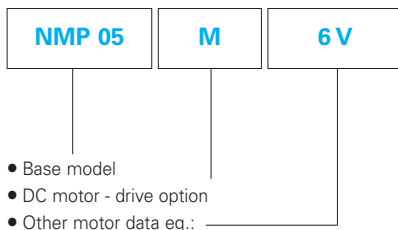

DRIVE OPTIONS

Our Micro Diaphragm Pumps are available with a choice of four different drive motors.

S - Standard

The pump is equipped with a standard dc motor.

M - DC motor with iron-free rotor

The pump is equipped with a dc motor with an iron-free rotor. It provides a higher level of performance than the S version and is ideal for more demanding operations.

L - DC motor with iron-free rotor

The pump is equipped with a dc motor which is based on the same technology as the M model but is even more robust and durable. This drive is ideal for higher operational. **The model L pass the EU guideline 89/336 for EMC.**

B - brushless DC motor

The pump is equipped with a brushless electronically commutated dc motor (electronics integrated in motor). The motor runs vibration and spark free, almost silently, is very dynamic and extremely durable. This model can be used permanently at all pressure levels.

In our extensive program you are sure to find the pump you need for your particular application.

KNF - the competent partner for vacuum and compressor technology. Especially for unusual problems. Call us and talk to our application engineers.

HINTS ON FUNCTION AND INSTALLATION

FUNCTION OF KNF MICRO DIAPHRAGM GAS SAMPLING PUMPS

An elastic diaphragm is moved up and down by an eccentric (see illustration). On the down-stroke it draws the air or gas being handled through the inlet valve. On the up-stroke the diaphragm forces the medium through the exhaust valve and out of the head. The compression chamber is hermetically separated from the drive mechanism by the diaphragm. The pumps transfer, evacuate and compress completely oil-free.

Diaphragm pump

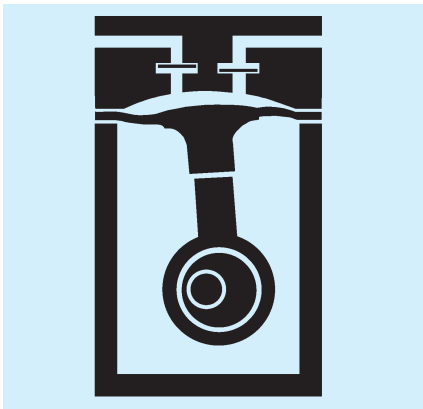

HINTS ON INSTALLATION AND OPERATION

- Range of use: Transferring air and gases at temperatures between + 5 °C and + 40 °C.
- Please check the compatibility of the materials of the pump head, diaphragm and valves with the medium.
- The KNF product line contains pumps suitable for pumping aggressive gases and vapors - please contact us.
- Permissible ambient temperature: between + 5 °C and + 40 °C.
- The standard pumps are not suitable for use in areas where there is a risk of explosion. In these cases there are other products in the KNF program - please ask us for details.
- The pumps are not designed to start against pressure or vacuum; when a pump is switched on the pressure in the suction and pressure lines must be atmospheric. Pumps that start against pressure or vacuum are available on request.
- To prevent the maximum operating pressure being exceeded, restriction or regulation of the air flow should only be carried out in the suction line.
- For the version with brushless motor the following also apply:
Caution! Incorrect lead connection will damage motor electronics!

- Components connected to the pump must be designed to withstand the pneumatic performance of the pump.
- Fit the pump at the highest point in the system, so that condensate cannot collect in the head of the pump - that prolongs working-life.

If you have any questions, please call our application engineers (see below for contact telephone number).