

多功能電子液晶顯示線性尺性能與操作說明書

FEATURES & OPERATION INSTRUCTION OF ELECTRONIC DIGITAL SCALE UNIT

本說明書用於 812 系列第三代單機能改進橫式電子液晶顯示線性尺，台灣製造。
This instruction is suitable for 812 series III of electronic digital scale unit (horizontal type), which is made in Taiwan.

1. 性能：

Features：

- 1-1. 測距：行程 0-2000mm 通用(除規格品，可指定需求長度)
Measuring Range：Suitable for 0-2000mm general type (Any indication of specific length can be made.)
- 1-2. 器差： $\pm(0.02+0.00005\times L)$ mm
Tolerance： $\pm(0.02+0.00005\times L)$ mm
- 1-3. 精度讀值：0.01mm / 0.001"
Resolution：0.01mm / 0.001"
- 1-4. 顯示範圍：依裝配顯示芯片規格(± 999.99 mm / 39.369")
Displaying Range：Depend on assembled latten type.(± 999.99 mm / 39.369")
- 1-5. 最高動速：1 M / Sec
Highest Motion：1 M / Sec
- 1-6. 輸出：可外接處理器及顯示器及開關鍵。
(使用特別附件之開關鍵，可在一般顯示與快算顯示作切換)
Output：Data can be connected to processor, monitor & on/off switch.
(A special switch button including for the conversion between normal displaying and swift displaying.)
- 1-7. 電源：採用水銀電池 SR44 1.55V X 1EA。
開啟壓 ON 開機 工作時數 2000 小時以上 一般使用約 1000 小時
(顯示幕數字閃爍時，提醒更換新電池，沒電後螢幕不顯示)
Power：Mercury battery SR44 1.55V X 1EA.
Push on/off button to turn on. Battery life over 1000 hr.
(When the displayed data is flashing to remind battery replacing.
The power run out could not display data.)
- 1-8. 工作環境：一般環境 5 - 40°C .相對溼度 80% 以下。
Operation Condition：Temperature 5-40°C.
Relative humidity lower than 80%

2. 操作：

Operation：

- 2-1. ON/OFF 鍵：ON — 開 / ZERO — 歸 0 OFF — 關
ON/OFF Button：ON—turn on / ZERO—zero setting OFF—turn off
- 2-2. IN/MM 鍵：IN 英制 MM 公制，可依使用單位作切換與計算。
IN/MM Button：Inch /minimeter interchange.

2-3. MODE 開關鍵：在尺體顯示座右上側，有下列功能，可循環操作：

MODE Switch Button : On upper right side of display unit. The following functions can be cycled operation.

壓一下：顯示幕字體左上方出現” H ” 英文，表示記憶狀態，再壓 ZERO 鍵，顯示幕字體上方出現” F ” 英文字 此時進入快算量測狀態，無法歸 0，如壓 ZERO 鍵跳回記憶，欲歸 0 需再壓一下 MODE 鍵，再壓 ZERO 鍵。

Push Once : Appears "H" on upper left side of the display monitor. It is on saving situation. And then push ZERO button and appears F on upper side of the display monitor. It is on measuring situation. No use for zero setting. To push ZERO button again for back to saving situation. To push MODE button and ZERO button for zero setting situation.

壓二下：顯示幕字體上方出現” H. S ” 二英文小字體，數字不能動，表示已作量測最大値之記憶設定，壓 ZERO 鍵一下，顯示幕字體上方出現” F. S ” 二英文字字體，此時開始進入量測，只能讀取比設定值小的量測值，跳脫壓 MODE 鍵一下。

Push Twice : Appears "H. S" on upper side of the display monitor with data holding. It means, which has been set on the maximum value of measuring. To push ZERO button again and appears "F. S". It is on measuring situation. But the value just can be read lower than the maximum value of setting. To push MODE button again for clearance.

壓三下：顯示幕字體上方出現” H. M ” 二英文字字體，數字不能動，表示已作量測最小値之記憶設定，壓 ZERO 鍵一下，顯示幕字體上方出現” F. M ” 二英文小字體，此時進入量測，只能讀取比設定值大的量測值，跳脫壓 MODE 鍵一下。

Push Thrice : Appears "H. M" on the display monitor with data holding. It means, which has been set on the minimum value of measuring. To push ZERO button again and appears "F. S". It is on measuring situation. But the value just can be read higher than the minimum value of setting. To push MODE button again for clearance.

壓四下：顯示幕字體恢復一般簡易功能狀態，螢幕無其它功能小體英文字。

Push Four Times : To recover the normal situation.

2-4. 電池蓋：更換電池依箭頭方向推開上搬即可。

Battery Cover : To replace battery as the arrow indication.

3. 注意事項：

Notes：

- 3-1. 使用前請以乾淨擦拭紙或布，沾少許清潔油，反覆擦拭保護表面，以除去表面凝結的水分、防銹油，並防鏽蝕。

Before using, take a clean wipe-paper or cloth with the clean oil soaking. And then wipe surface to get rid of condensed water and antirust-oil to prevent rusting.

- 3-2. 請在機器電機維修時，暫時將電池拔下，以防止低電壓漏電，毀損 IC。

To take off the battery before maintenance for IC and display unit protection.

- 3-3. 保護膜污垢應以中性清潔劑沾布擦拭，嚴重油垢以汽車用粗蠟擦拭，勿用溶劑（像酒精、甲苯、松香水）之類清潔，以免腐蝕尺體保護膜。

Any dirt on the protected sticker should be cleaned with the clean cloth by soft cleaner. If it is heavy dirt please do not use solvent (such as alcohol, solvent, paint thinner with rosin additive) to avoid any corrosion.

- 3-4. 在下雨天閃電很接近時，請關閉使用，平時一般狀況不關機。

When the lighting are thunder are coming please tune off without using.

- 3-5. 尺體安裝後一定要作校直動作，如有撞擊到，請確認尺體與機器垂直度，如有偏移，應自行以磁性座掛百分槓桿表校正，以防止故障。

After assemble, this scare has to make the vertical calibration. There are any hitting please make sure the squareness between scare and machine. If it meets deflection please use a indicator to calibrate the squareness.

- 3-6. MODE 鍵右側外接插口有引線四條，當液晶顯示在幕左上角出現 ” H ” 時，為 HOLD 記憶鎖定狀態，如果無法以 MODE 鍵消除應以導線將第一條引線接觸第四條引線，作消除記憶，動作完成出現 0.00mm 顯示，也可把電池拔除，壓著 ON/OFF 鍵再裝電池，重新開機。

There are four interfaces at right side of MODE button. When appears "H" on upper left side of the display monitor it means HOLD on saving situation. If it can't be cleared by MODE button please take the conducting wire (from interface I) to touch another conducting wire (from interface IV) to clear this saving situation. It would appear 0.00mm after completion. Also, we can remove the battery. And then put in the battery with ON/OFF button pushing and turn on again.

- 3-7. 當機時顯示螢幕出現液晶所有顯示字體與數字，需卸除電池，壓著 ON/OFF 鍵再裝電池，重新開機。

When appears all letters it means - crashed. Please remove the battery. And then put in the battery with ON/OFF button pushing and turn on again.

- 3-8. 如從市場買的 LR44 / 1.5V 電池效果不佳，電壓不足 1.3V 時，表示電池放置過久，自然放電因素，已能量耗損，請裝用電壓+電流足夠新電池，以免影響使用。

If the battery LR44 / 1.5V bought from the market does not work satisfactorily (volt under 1.3V). The power may wear down. Because a long time storage cause

the automatic discharge. Please replace a new a new one.

外觀尺寸圖示：其它詳細規格上網址 www.goldenhope.com.tw 點選產品櫥窗，進入以表列看代理精密量具，點電子數顯線性標尺，可參閱。

Figure of Appearance Dimensions : Please refer our website www.goldenhope.com.tw

This part is not included.

凹槽背鈕與鋼珠球頭為另購組件不附屬

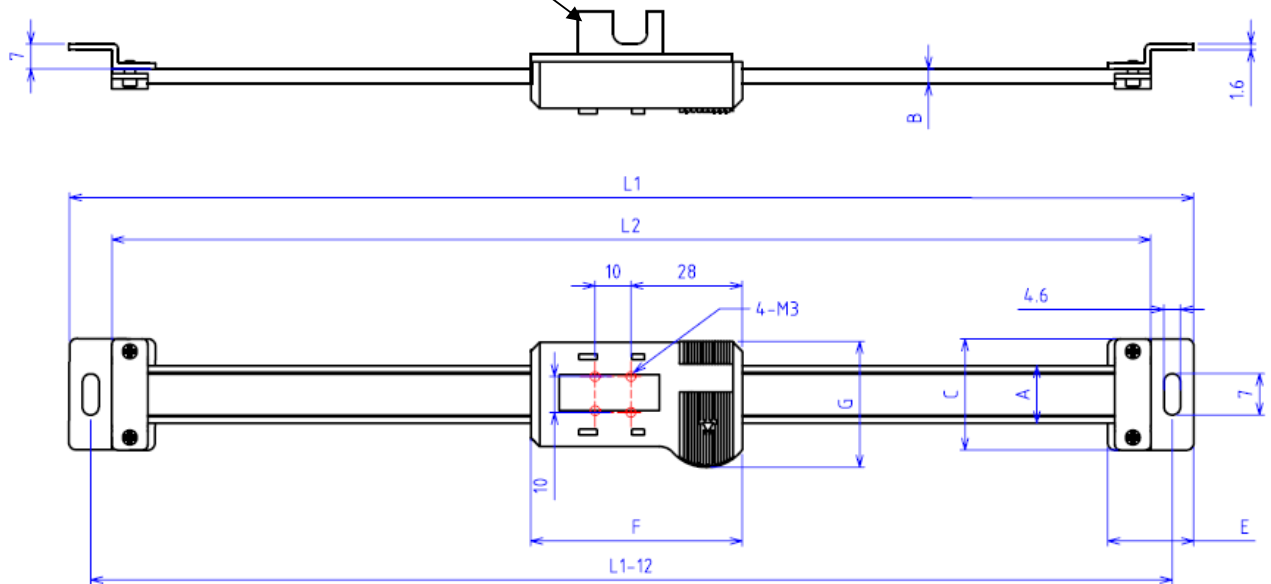

本圖示為 100/150/200/300 所採用規範